

COMBINED SYNOPSIS/SOLICITATION FOR COMMERCIAL ITEMS

General Information

Document Type: Combined Synopsis/Solicitation

Solicitation Number: NIEHS-6388823-OM

Posted Date: August 1, 2022

Original Response Date: August 12, 2022

Current Response Date: August 12, 2022

Product or Service Code: 5810 – Communications Security Equipment and Components

Set Aside: Full and Open Competition

NAICS Code: 517919 – All Other Telecommunication

Contracting Office Address

National Institute of Environmental Health Sciences (NIEHS)

Office of Acquisitions

530 Davis Drive

Morrisville, NC 27560

Description

This is a combined synopsis/solicitation for commercial items prepared in accordance with the format in the Federal Acquisition Regulation (FAR) subpart 12.6, "Streamlined Procedures for Evaluation and Solicitation for Commercial Items," as supplemented with additional information included in this notice. This announcement constitutes the only solicitation; quotes are being requested, and a written solicitation document will not be issued. This solicitation is a request for quote (RFQ). The solicitation document and incorporated provisions and clauses are those in effect through Federal Acquisition Circular (FAC) 2022-05 March 7, 2022. This acquisition will be processed under FAR Part 13 Simplified Acquisition Procedures (SAP). The solicitation documents and incorporated provisions and clauses are those in effect through Federal Acquisition Circular (FAC) 2022-05 March 7, 2022.

The associated North American Industrial Classification System (NAICS) code for this procurement is 517919, with a small business size standard of \$35M.

Statement of Work

The National Institutes of Environmental Health Sciences (NIEHS) in Research Triangle Park (RTP) is soliciting a vendor to remove and replace two (2) existing Code Blue Emergency units.

Current Set up

The existing call stations currently operate with a hardwire analog telephone connection and access to a 110-volt power source. One unit is a standard Code Blue tower device and located in the parking lot. The second unit is a pole mount device and located at the front entrance of the building. These units have built-in electrical circuitry to allow operation at night. Internal batteries are utilized for operation during the day.

Requirements

Remove the existing two (2) Code Blue Emergency call stations and install two (2) replacement Emergency call stations that utilize VoIP technology. The replacement device in the parking lot shall be a tower style and the replacement device at the front entrance of the building shall be a pedestal or pole style. Replacement devices shall be compatible with Cisco UCM7.1 and Cisco UCM8.6

Specifications

The two (2) replacement Emergency call stations shall meet or exceed the specifications of the Talkphone TF-VoIP500E Call Station. Both call stations shall include a blue light, necessary mount kits (tower, pole and/or wall mounts), Banding kit and extenders if necessary.

The tower mount device shall meet or exceed the specifications of the Talkphone TF-ETPMTE Eco Tower Mount with a blue light.

The wall mount device shall meet or exceed the specifications of the Talkphone TF-ETPWMS Wall Mount.

Specifications of both call stations, tower and mounts are provided in **Attachments A, B and C**.

The Contractor shall:

1. Provide a detailed project schedule within 10 calendar days of award.
2. Provide all equipment, labor and materials to remove two (2) existing Code Blue units and return the removed Code Blue units to the NIEHS COR.
3. Provide all equipment, materials, labor, parts, mount kits, banding kits, extenders, cables and miscellaneous materials to install two (2) new emergency call units.
4. Install two (2) new emergency call stations.
5. Provide each device in Red with white graphics - 'EMERGENCY'.
6. Provide a minimum of one-year warranty from date of installation on all products, parts and labor.
7. Provide a plan to demonstrate how this project will be accomplished. The plan must include a timeline and a kick-off meeting with NIEHS to discuss the project prior to project start.

8. provide a minimum of two (2) references of comparable project requirements to include the business name, point of contact information (name, telephone number, email address, etc.) and a description of the project completed with the dollar amount.

The contractor shall provide the following items as appropriate upon project close out:

1. Warranties
2. Spare Parts Data
3. Preventative Maintenance
4. Operation and Maintenance Manuals
5. As-Built Drawings

NIEHS shall provide:

1. Access to all areas on the NIEHS campus necessary for installation and testing of Call stations including but not limited to electrical access points, electrical panels, LAN closets, etc.
2. VoIP telephone number, provisioning, and SIP addresses for each Call Station.
3. Electrical access point for each Call station.

Period of performance

Final construction must be completed within 90 calendar days from date of award.

Place of Delivery

NIEHS
530 Davis Drive
POC: Treva Bunch
Morrisville, NC 27560

Evaluation Method

The Government will award a contract resulting from this solicitation to the responsible quoter whose offer conforming to the solicitation will be most advantageous to the Government, price and other factors considered. The following factors shall be used to evaluate offers:

1. Lowest Price Technically Acceptable

Questions

Submission shall be received no later than August 12, 2022, 4:00 pm Eastern time. Any questions or concerns regarding this solicitation should be forwarded in writing via e-mail to the Contract Specialist/Contracting Officer listed below no later than August 5, 2022. No questions will be accepted or answered via telephone.

All persons listed below must be included on all questions submitted.

Points of Contact

Odessa McGlown

Contract Specialist

Odessa.mcglown@nih.gov

Henry Daniels

Branch Chief, Station Support

Henry.daniels@nih.gov

All interested companies shall provide quotes for supplies and labor. “Lowest Price” shall be based on *Total: Equipment and Labor*.

Quote

Quantity	Description	Unit Price	Extended Price
Total: Equipment			
	Labor		
Total: Labor			
Total: Equipment and Labor			

This is an open-market combined synopsis/solicitation for commercial products as defined herein. The government intends to award a purchase order as a result of this combined synopsis/solicitation that will include the terms and conditions set forth herein.

Offerors must complete annual representations and certifications on-line at <https://www.sam.gov> in accordance with FAR 52.212-3, “Offerors Representations and Certifications–Commercial Items.” If paragraph (j) of the provision is applicable, a written submission is required.

The following contract clauses apply to this acquisition:

- FAR 52.212-1, Instructions to Offerors-Commercial Items (Nov 2021)

- FAR 52.212-2 Evaluation—Commercial Products and Commercial Services (Nov 2021)
- FAR 52.204-24 Representation Regarding Certain Telecommunications and Video Surveillance Services or Equipment (Nov 2021)
- FAR 52.204-26 Covered Telecommunications Equipment or Services-Representation (Oct 2020)

CLAUSES INCORPORATED BY REFERENCE

52.204-4	Printed or Copied Double-Sided on Postconsumer Fiber Content Paper (May 2011)
52.204-25	Prohibition on Contracting for Certain Telecommunications and Video Surveillance Services or Equipment (Nov 2021)
52.212-4	Contract Terms and Conditions—Commercial Products and Commercial Services (Nov 2021)
352.203-70	Anti-Lobbying (Dec 2015)
352.222-70	Contractor Cooperation in Equal Employment Opportunity Investigations (Dec 2015)
352.223-70	Safety and Health (Dec 2015)
352.227-70	Publications and Publicity (Dec 2015)
352.239-74	Electronic and Information Technology Accessibility (Dec 2015)

CLAUSES INCORPORATED BY FULL TEXT

52.212-5 Contract Terms and Conditions Required To Implement Statutes or Executive Orders—Commercial Products and Commercial Services

Contract Terms and Conditions Required To Implement Statutes or Executive Orders—Commercial Products and Commercial Services (**Jan 2022**)

(a) The Contractor shall comply with the following Federal Acquisition Regulation (FAR) clauses, which are incorporated in this contract by reference, to implement provisions of law or Executive orders applicable to acquisitions of commercial products and commercial services:

(1) [52.203-19](#), Prohibition on Requiring Certain Internal Confidentiality Agreements or Statements (JAN 2017) (section 743 of Division E, Title VII, of the Consolidated and Further Continuing Appropriations Act, 2015 (Pub. L. 113-235) and its successor provisions in subsequent appropriations acts (and as extended in continuing resolutions)).

(2) [52.204-23](#), Prohibition on Contracting for Hardware, Software, and Services Developed or Provided by Kaspersky Lab and Other Covered Entities (NOV 2021) (Section 1634 of Pub. L. 115-91).

(3) [52.204-25](#), Prohibition on Contracting for Certain Telecommunications and Video Surveillance Services or Equipment. (NOV 2021) (Section 889(a)(1)(A) of Pub. L. 115-232).

(4) [52.209-10](#), Prohibition on Contracting with Inverted Domestic Corporations (NOV 2015).

(5) [52.233-3](#), Protest After Award (AUG 1996) ([31 U.S.C. 3553](#)).

(6) [52.233-4](#), Applicable Law for Breach of Contract Claim (OCT 2004) (Public Laws 108-77 and 108-78 ([19 U.S.C. 3805 note](#))).

(b) The Contractor shall comply with the FAR clauses in this paragraph (b) that the Contracting Officer has indicated as being incorporated in this contract by reference to implement provisions of law or Executive orders applicable to acquisitions of commercial products and commercial services:

[Contracting Officer check as appropriate.]

___ (1) [52.203-6](#), Restrictions on Subcontractor Sales to the Government (JUN 2020), with *Alternate I* (NOV 2021) ([41 U.S.C. 4704](#) and [10 U.S.C. 2402](#)).

X (2) [52.203-13](#), Contractor Code of Business Ethics and Conduct (NOV 2021) ([41 U.S.C. 3509](#))).

X (3) [52.203-15](#), Whistleblower Protections under the American Recovery and Reinvestment Act of 2009 (JUN 2010) (Section 1553 of Pub. L. 111-5). (Applies to contracts funded by the American Recovery and Reinvestment Act of 2009.)

X (4) [52.204-10](#), Reporting Executive Compensation and First-Tier Subcontract Awards (JUN 2020) (Pub. L. 109-282) ([31 U.S.C. 6101 note](#)).

___ (5) [Reserved].

___ (6) [52.204-14](#), Service Contract Reporting Requirements (OCT 2016) (Pub. L. 111-117, section 743 of Div. C).

___ (7) [52.204-15](#), Service Contract Reporting Requirements for Indefinite-Delivery Contracts (OCT 2016) (Pub. L. 111-117, section 743 of Div. C).

___ (8) [52.209-6](#), Protecting the Government's Interest When Subcontracting with Contractors Debarred, Suspended, or Proposed for Debarment. (NOV 2021) ([31 U.S.C. 6101 note](#)).

___ (9) [52.209-9](#), Updates of Publicly Available Information Regarding Responsibility Matters (OCT 2018) ([41 U.S.C. 2313](#)).

___ (10) [Reserved].

___ (11) [52.219-3](#), Notice of HUBZone Set-Aside or Sole-Source Award (SEP 2021) ([15 U.S.C. 657a](#)).

___ (12) [52.219-4](#), Notice of Price Evaluation Preference for HUBZone Small Business Concerns (SEP 2021) (if the offeror elects to waive the preference, it shall so indicate in its offer) ([15 U.S.C. 657a](#)).

___ (13) [Reserved]

___ (14) (i) [52.219-6](#), Notice of Total Small Business Set-Aside (NOV 2020) ([15 U.S.C. 644](#)).

___ (ii) Alternate I (MAR 2020) of [52.219-6](#).

___ (15) (i) [52.219-7](#), Notice of Partial Small Business Set-Aside (NOV 2020) ([15 U.S.C. 644](#)).

- __ (ii) Alternate I (MAR 2020) of [52.219-7](#).
- (3).
 - __ (16) [52.219-8](#), Utilization of Small Business Concerns (OCT 2018) ([15 U.S.C. 637\(d\)\(2\)](#)) and
 - __ (17) (i) [52.219-9](#), Small Business Subcontracting Plan (NOV 2021) ([15 U.S.C. 637\(d\)\(4\)](#)).
 - __ (ii) Alternate I (NOV 2016) of [52.219-9](#).
 - __ (iii) Alternate II (NOV 2016) of [52.219-9](#).
 - __ (iv) Alternate III (JUN 2020) of [52.219-9](#).
 - __ (v) Alternate IV (SEP 2021) of [52.219-9](#).
 - __ (18) (i) [52.219-13](#), Notice of Set-Aside of Orders (MAR 2020) ([15 U.S.C. 644\(r\)](#)).
 - __ (ii) Alternate I (MAR 2020) of [52.219-13](#).
 - __ (19) [52.219-14](#), Limitations on Subcontracting (SEP 2021) ([15 U.S.C. 637s](#)).
 - __ (20) [52.219-16](#), Liquidated Damages—Subcontracting Plan (SEP 2021) ([15 U.S.C. 637\(d\)\(4\)\(F\)\(i\)](#)).
 - __ (21) [52.219-27](#), Notice of Service-Disabled Veteran-Owned Small Business Set-Aside (SEP 2021) ([15 U.S.C. 657f](#)).
 - __ (22) (i) [52.219-28](#), Post Award Small Business Program Rerepresentation (SEP 2021) ([15 U.S.C. 632\(a\)\(2\)](#)).
 - __ (ii) Alternate I (MAR 2020) of [52.219-28](#).
 - __ (23) [52.219-29](#), Notice of Set-Aside for, or Sole-Source Award to, Economically Disadvantaged Women-Owned Small Business Concerns (SEP 2021) ([15 U.S.C. 637\(m\)](#)).
 - __ (24) [52.219-30](#), Notice of Set-Aside for, or Sole-Source Award to, Women-Owned Small Business Concerns Eligible Under the Women-Owned Small Business Program (SEP 2021) ([15 U.S.C. 637\(m\)](#)).
 - __ (25) [52.219-32](#), Orders Issued Directly Under Small Business Reserves (MAR 2020) ([15 U.S.C. 644\(r\)](#)).
 - __ (26) [52.219-33](#), Nonmanufacturer Rule (SEP 2021) ([15U.S.C. 637\(a\)\(17\)](#)).
 - __X_ (27) [52.222-3](#), Convict Labor (JUN 2003) (E.O.11755).
 - __ (28) [52.222-19](#), Child Labor-Cooperation with Authorities and Remedies (JAN2020) (E.O.13126).

- X__ (29) [52.222-21](#), Prohibition of Segregated Facilities (APR 2015).
- _X_ (30) (i) [52.222-26](#), Equal Opportunity (SEP 2016) (E.O.11246).
- __ (ii) Alternate I (FEB 1999) of [52.222-26](#).
- _X_ (31) (i) [52.222-35](#), Equal Opportunity for Veterans (JUN 2020) ([38 U.S.C. 4212](#)).
- __ (ii) Alternate I (JUL 2014) of [52.222-35](#).
- _X_ (32) (i) [52.222-36](#), Equal Opportunity for Workers with Disabilities (JUN 2020) ([29 U.S.C. 793](#)).
- __ (ii) Alternate I (JUL 2014) of [52.222-36](#).
- _X_ (33) [52.222-37](#), Employment Reports on Veterans (JUN 2020) ([38 U.S.C. 4212](#)).
- __ (34) [52.222-40](#), Notification of Employee Rights Under the National Labor Relations Act (DEC 2010) (E.O. 13496).
- __ (35) (i) [52.222-50](#), Combating Trafficking in Persons (NOV 2021) ([22 U.S.C. chapter 78](#) and E.O. 13627).
- __ (ii) Alternate I (MAR 2015) of [52.222-50](#) ([22 U.S.C. chapter 78](#) and E.O. 13627).
- __ (36) [52.222-54](#), Employment Eligibility Verification (NOV 2021) . (Executive Order 12989). (Not applicable to the acquisition of commercially available off-the-shelf items or certain other types of commercial products or commercial services as prescribed in FAR [22.1803](#).)
- __ (37) (i) [52.223-9](#), Estimate of Percentage of Recovered Material Content for EPA– Designated Items (May 2008) ([42 U.S.C. 6962\(c\)\(3\)\(A\)\(ii\)](#)). (Not applicable to the acquisition of commercially available off-the-shelf items.)
- __ (ii) Alternate I (MAY 2008) of [52.223-9](#) ([42 U.S.C. 6962\(i\)\(2\)\(C\)](#)). (Not applicable to the acquisition of commercially available off-the-shelf items.)
- _X_ (38) [52.223-11](#), Ozone-Depleting Substances and High Global Warming Potential Hydrofluorocarbons (Jun 2016) (E.O. 13693).
- __ (39) [52.223-12](#), Maintenance, Service, Repair, or Disposal of Refrigeration Equipment and Air Conditioners (JUN 2016) (E.O. 13693).
- __ (40) (i) [52.223-13](#), Acquisition of EPEAT®-Registered Imaging Equipment (JUN 2014) (E.O.s 13423 and 13514).
- __ (ii) Alternate I (OCT 2015) of [52.223-13](#).
- __ (41) (i) [52.223-14](#), Acquisition of EPEAT®-Registered Televisions (JUN 2014) (E.O.s 13423 and 13514).

__ (ii) Alternate I (Jun2014) of [52.223-14](#).

__ (42) [52.223-15](#), Energy Efficiency in Energy-Consuming Products (MAY 2020) ([42 U.S.C. 8259b](#)).

__ (43) (i) [52.223-16](#), Acquisition of EPEAT®-Registered Personal Computer Products (OCT 2015) (E.O.s 13423 and 13514).

__ (ii) Alternate I (JUN 2014) of [52.223-16](#).

__ (44) [52.223-18](#), Encouraging Contractor Policies to Ban Text Messaging While Driving (JUN 2020) (E.O. 13513).

__ (45) [52.223-20](#), Aerosols (JUN 2016) (E.O. 13693).

__ (46) [52.223-21](#), Foams (Jun2016) (E.O. 13693).

__ (47) (i) [52.224-3](#) Privacy Training (JAN 2017) (5 U.S.C. 552 a).

__ (ii) Alternate I (JAN 2017) of [52.224-3](#).

__ (48) [52.225-1](#), Buy American-Supplies (NOV 2021) ([41 U.S.C. chapter 83](#)).

__ (49) (i) [52.225-3](#), Buy American-Free Trade Agreements-Israeli Trade Act (NOV 2021) ([41 U.S.C. chapter 83](#), [19 U.S.C. 3301](#) note, [19 U.S.C. 2112](#) note, [19 U.S.C. 3805](#) note, [19 U.S.C. 4001](#) note, Pub. L. 103-182, 108-77, 108-78, 108-286, 108-302, 109-53, 109-169, 109-283, 110-138, 112-41, 112-42, and 112-43).

__ (ii) Alternate I (JAN 2021) of [52.225-3](#).

__ (iii) Alternate II (JAN 2021) of [52.225-3](#).

__ (iv) Alternate III (JAN 2021) of [52.225-3](#).

__ (50) [52.225-5](#), Trade Agreements (OCT 2019) ([19 U.S.C. 2501](#), *et seq.*, [19 U.S.C. 3301](#) note).

__ (51) [52.225-13](#), Restrictions on Certain Foreign Purchases (FEB 2021) (E.O.'s, proclamations, and statutes administered by the Office of Foreign Assets Control of the Department of the Treasury).

__ (52) [52.225-26](#), Contractors Performing Private Security Functions Outside the United States (Oct 2016) (Section 862, as amended, of the National Defense Authorization Act for Fiscal Year 2008; [10 U.S.C. 2302](#)Note).

__ (53) [52.226-4](#), Notice of Disaster or Emergency Area Set-Aside (Nov2007) ([42 U.S.C. 5150](#)).

___ (54) [52.226-5](#), Restrictions on Subcontracting Outside Disaster or Emergency Area (Nov2007) ([42 U.S.C. 5150](#)).

___ (55) [52.229-12](#), Tax on Certain Foreign Procurements (FEB 2021).

___ (56) [52.232-29](#), Terms for Financing of Purchases of Commercial Products and Commercial Services (NOV 2021) ([41 U.S.C. 4505](#), [10 U.S.C. 2307\(f\)](#)).

___ (57) [52.232-30](#), Installment Payments for Commercial Products and Commercial Services (NOV 2021) ([41 U.S.C. 4505](#), [10 U.S.C. 2307\(f\)](#)).

___ (58) [52.232-33](#), Payment by Electronic Funds Transfer-System for Award Management (OCT2018) ([31 U.S.C. 3332](#)).

___ (59) [52.232-34](#), Payment by Electronic Funds Transfer-Other than System for Award Management (Jul 2013) ([31 U.S.C. 3332](#)).

___ (60) [52.232-36](#), Payment by Third Party (MAY 2014) ([31 U.S.C. 3332](#)).

___ (61) [52.239-1](#), Privacy or Security Safeguards (AUG 1996) ([5 U.S.C. 552a](#)).

X (62) [52.242-5](#), Payments to Small Business Subcontractors (JAN 2017) ([15 U.S.C. 637\(d\)\(13\)](#)).

___ (63) (i) [52.247-64](#), Preference for Privately Owned U.S.-Flag Commercial Vessels (NOV 2021) ([46 U.S.C. 55305](#) and [10 U.S.C. 2631](#)).

___ (ii) Alternate I (APR 2003) of [52.247-64](#).

___ (iii) Alternate II (NOV 2021) of [52.247-64](#).

(c) The Contractor shall comply with the FAR clauses in this paragraph (c), applicable to commercial services, that the Contracting Officer has indicated as being incorporated in this contract by reference to implement provisions of law or Executive orders applicable to acquisitions of commercial products and commercial services:

[*Contracting Officer check as appropriate.*]

___ (1) [52.222-41](#), Service Contract Labor Standards (AUG 2018) ([41 U.S.C. chapter 67](#)).

___ (2) [52.222-42](#), Statement of Equivalent Rates for Federal Hires (MAY 2014) ([29 U.S.C. 206](#) and [41 U.S.C. chapter 67](#)).

___ (3) [52.222-43](#), Fair Labor Standards Act and Service Contract Labor Standards-Price Adjustment (Multiple Year and Option Contracts) (AUG 2018) ([29 U.S.C. 206](#) and [41 U.S.C. chapter 67](#)).

___ (4) [52.222-44](#), Fair Labor Standards Act and Service Contract Labor Standards-Price Adjustment (May 2014) ([29U.S.C.206](#) and [41 U.S.C. chapter 67](#)).

___ (5) [52.222-51](#), Exemption from Application of the Service Contract Labor Standards to Contracts for Maintenance, Calibration, or Repair of Certain Equipment-Requirements (May 2014) ([41 U.S.C. chapter 67](#)).

___ (6) [52.222-53](#), Exemption from Application of the Service Contract Labor Standards to Contracts for Certain Services-Requirements (MAY 2014) ([41 U.S.C. chapter 67](#)).

___ (7) [52.222-55](#), Minimum Wages Under Executive Order 13658 (NOV 2020).

___ (8) [52.222-62](#), Paid Sick Leave Under Executive Order 13706 (JAN 2017) (E.O. 13706).

___ (9) [52.226-6](#), Promoting Excess Food Donation to Nonprofit Organizations (Jun 2020) ([42 U.S.C. 1792](#)).

(d) *Comptroller General Examination of Record*. The Contractor shall comply with the provisions of this paragraph (d) if this contract was awarded using other than sealed bid, is in excess of the simplified acquisition threshold, as defined in FAR [2.101](#), on the date of award of this contract, and does not contain the clause at [52.215-2](#), Audit and Records-Negotiation.

(1) The Comptroller General of the United States, or an authorized representative of the Comptroller General, shall have access to and right to examine any of the Contractor's directly pertinent records involving transactions related to this contract.

(2) The Contractor shall make available at its offices at all reasonable times the records, materials, and other evidence for examination, audit, or reproduction, until 3 years after final payment under this contract or for any shorter period specified in FAR subpart [4.7](#), Contractor Records Retention, of the other clauses of this contract. If this contract is completely or partially terminated, the records relating to the work terminated shall be made available for 3 years after any resulting final termination settlement. Records relating to appeals under the disputes clause or to litigation or the settlement of claims arising under or relating to this contract shall be made available until such appeals, litigation, or claims are finally resolved.

(3) As used in this clause, records include books, documents, accounting procedures and practices, and other data, regardless of type and regardless of form. This does not require the Contractor to create or maintain any record that the Contractor does not maintain in the ordinary course of business or pursuant to a provision of law.

(e)

(1) Notwithstanding the requirements of the clauses in paragraphs (a), (b), (c), and (d) of this clause, the Contractor is not required to flow down any FAR clause, other than those in this paragraph (e)(1) in a subcontract for commercial products or commercial services. Unless otherwise indicated below, the extent of the flow down shall be as required by the clause-

(i) [52.203-13](#), Contractor Code of Business Ethics and Conduct (NOV 2021) ([41 U.S.C. 3509](#)).

(ii) [52.203-19](#), Prohibition on Requiring Certain Internal Confidentiality Agreements or Statements (Jan 2017) (section 743 of Division E, Title VII, of the Consolidated and Further Continuing

Appropriations Act, 2015 (Pub. L. 113-235) and its successor provisions in subsequent appropriations acts (and as extended in continuing resolutions)).

(iii) [52.204-23](#), Prohibition on Contracting for Hardware, Software, and Services Developed or Provided by Kaspersky Lab and Other Covered Entities (NOV 2021) (Section 1634 of Pub. L. 115-91).

(iv) [52.204-25](#), Prohibition on Contracting for Certain Telecommunications and Video Surveillance Services or Equipment. (NOV 2021) (Section 889(a)(1)(A) of Pub. L. 115-232).

(v) [52.219-8](#), Utilization of Small Business Concerns (OCT 2018) ([15 U.S.C. 637\(d\)\(2\)](#) and (3)), in all subcontracts that offer further subcontracting opportunities. If the subcontract (except subcontracts to small business concerns) exceeds the applicable threshold specified in FAR [19.702\(a\)](#) on the date of subcontract award, the subcontractor must include [52.219-8](#) in lower tier subcontracts that offer subcontracting opportunities.

(vi) [52.222-21](#), Prohibition of Segregated Facilities (APR 2015).

(vii) [52.222-26](#), Equal Opportunity (SEP 2015) (E.O.11246).

(viii) [52.222-35](#), Equal Opportunity for Veterans (JUN 2020) ([38 U.S.C. 4212](#)).

(ix) [52.222-36](#), Equal Opportunity for Workers with Disabilities (JUN 2020) ([29 U.S.C. 793](#)).

(x) [52.222-37](#), Employment Reports on Veterans (JUN 2020) ([38 U.S.C. 4212](#)).

(xi) [52.222-40](#), Notification of Employee Rights Under the National Labor Relations Act (DEC 2010) (E.O. 13496). Flow down required in accordance with paragraph (f) of FAR clause [52.222-40](#).

(xii) [52.222-41](#), Service Contract Labor Standards (AUG 2018) ([41 U.S.C. chapter 67](#)).

(xiii)

(A) [52.222-50](#), Combating Trafficking in Persons (NOV 2021) ([22 U.S.C. chapter 78](#) and E.O 13627).

(B) Alternate I (MAR 2015) of [52.222-50](#) ([22 U.S.C. chapter 78](#) and E.O. 13627).

(xiv) [52.222-51](#), Exemption from Application of the Service Contract Labor Standards to Contracts for Maintenance, Calibration, or Repair of Certain Equipment-Requirements (MAY2014) ([41 U.S.C. chapter 67](#)).

(xv) [52.222-53](#), Exemption from Application of the Service Contract Labor Standards to Contracts for Certain Services-Requirements (MAY 2014) ([41 U.S.C. chapter 67](#)).

(xvi) [52.222-54](#), Employment Eligibility Verification (NOV 2021) (E.O. 12989).

(xvii) [52.222-55](#), Minimum Wages Under Executive Order 13658 (NOV 2020).

(xviii) [52.222-62](#), Paid Sick Leave Under Executive Order 13706 (JAN 2017) (E.O. 13706).

(xix)

(A) [52.224-3](#), Privacy Training (Jan 2017) ([5 U.S.C. 552a](#)).

(B) Alternate I (JAN 2017) of [52.224-3](#).

(xx) [52.225-26](#), Contractors Performing Private Security Functions Outside the United States (OCT 2016) (Section 862, as amended, of the National Defense Authorization Act for Fiscal Year 2008; [10 U.S.C. 2302 Note](#)).

(xxi) [52.226-6](#), Promoting Excess Food Donation to Nonprofit Organizations (JUN 2020) ([42 U.S.C. 1792](#)). Flow down required in accordance with paragraph (e) of FAR clause 52.226-6.

(xxii) [52.247-64](#), Preference for Privately Owned U.S.-Flag Commercial Vessels (NOV 2021) ([46 U.S.C. 55305](#) and [10 U.S.C. 2631](#)). Flow down required in accordance with paragraph (d) of FAR clause 52.247-64.

(2) While not required, the Contractor may include in its subcontracts for commercial products and commercial services a minimal number of additional clauses necessary to satisfy its contractual obligations.

(End of clause)

Alternate I (FEB 2000). As prescribed in [12.301\(b\)\(4\)\(i\)](#), delete paragraph (d) from the basic clause, redesignate paragraph (e) as paragraph (d), and revise the reference to "paragraphs (a), (b), (c), or (d) of this clause" in the redesignated paragraph (d) to read "paragraphs (a), (b), and (c) of this clause".

Alternate II. (NOV 2021) As prescribed in [12.301\(b\)\(4\)\(ii\)](#), substitute the following paragraphs (d)(1) and (e)(1) for paragraphs (d)(1) and (e)(1) of the basic clause as follows:

(d)(1) The Comptroller General of the United States, an appropriate Inspector General appointed under section 3 or 8 G of the Inspector General Act of 1978 ([5 U.S.C. App.](#)), or an authorized representative of either of the foregoing officials shall have access to and right to—

(i) Examine any of the Contractor's or any subcontractors' records that pertain to, and involve transactions relating to, this contract; and

(ii) Interview any officer or employee regarding such transactions.

(e)(1) Notwithstanding the requirements of the clauses in paragraphs (a), (b), and (c), of this clause, the Contractor is not required to flow down any FAR clause in a subcontract for commercial products or commercial services, other than—

(i) *Paragraph (d) of this clause*. This paragraph flows down to all subcontracts, except the authority of the Inspector General under paragraph (d)(1)(ii) does not flow down; and

(ii) *Those clauses listed in this paragraph (e)(1).* Unless otherwise indicated below, the extent of the flow down shall be as required by the clause-

(A) [52.203-13](#), Contractor Code of Business Ethics and Conduct (NOV 2021) ([41 U.S.C. 3509](#)).

(B) [52.203-15](#), Whistleblower Protections Under the American Recovery and Reinvestment Act of 2009 (JUN 2010) (Section 1553 of Pub. L. 111-5).

(C) 52.204-23, Prohibition on Contracting for Hardware, Software, and Services Developed or Provided by Kaspersky Lab and Other Covered Entities (NOV 2021) (Section 1634 of Pub. L. 115-91).

(D) 52.204-25, Prohibition on Contracting for Certain Telecommunications and Video Surveillance Services or Equipment. (NOV 2021) (Section 889(a)(1)(A) of Pub. L. 115-232).

(E) [52.219-8](#), Utilization of Small Business Concerns (OCT 2018) ([15 U.S.C. 637\(d\)\(2\) and \(3\)](#)), in all subcontracts that offer further subcontracting opportunities. If the subcontract (except subcontracts to small business concerns) exceeds the applicable threshold specified in FAR [19.702\(a\)](#) on the date of subcontract award, the subcontractor must include [52.219-8](#) in lower tier subcontracts that offer subcontracting opportunities.

(F) [52.222-21](#), Prohibition of Segregated Facilities (APR 2015).

(G) [52.222-26](#), Equal Opportunity (SEP 2016) (E.O. 11246).

(H) [52.222-35](#), Equal Opportunity for Veterans (JUN 2020) ([38 U.S.C. 4212](#)).

(I) [52.222-36](#), Equal Opportunity for Workers with Disabilities (JUN 2020) ([29 U.S.C. 793](#)).

(J) [52.222-40](#), Notification of Employee Rights Under the National Labor Relations Act (DEC 2010) (E.O. 13496). Flow down required in accordance with paragraph (f) of FAR clause [52.222-40](#).

(K) [52.222-41](#), Service Contract Labor Standards (AUG 2018) ([41 U.S.C. chapter 67](#)).

(L) ___ (I) [52.222-50](#), Combating Trafficking in Persons (NOV 2021) ([22 U.S.C. chapter 78](#) and E.O 13627).

___ (2) Alternate I (MAR 2015) of [52.222-50](#) ([22 U.S.C. chapter 78](#) and E.O. 13627).

(M) [52.222-51](#), Exemption from Application of the Service Contract Labor Standards to Contracts for Maintenance, Calibration, or Repair of Certain Equipment-Requirements (May 2014) ([41 U.S.C. chapter 67](#)).

(N) [52.222-53](#), Exemption from Application of the Service Contract Labor Standards to Contracts for Certain Services-Requirements (MAY 2014) ([41 U.S.C. chapter 67](#)).

12989). (O) [52.222-54](#), Employment Eligibility Verification (NOV 2021) (Executive Order

(P) [52.222-55](#), Minimum Wages Under Executive Order 13658 (NOV 2020).

(Q) [52.222-62](#), Paid Sick Leave Under Executive Order 13706 (JAN 2017) (E.O. 13706).

(R) (I) [52.224-3](#), Privacy Training (JAN 2017) ([5 U.S.C. 552a](#)).

(2) Alternate I (JAN 2017) of [52.224-3](#).

(S) [52.225-26](#), Contractors Performing Private Security Functions Outside the United States (Oct 2016) (Section 862, as amended, of the National Defense Authorization Act for Fiscal Year 2008; [10 U.S.C. 2302](#) Note).

(T) [52.226-6](#), Promoting Excess Food Donation to Nonprofit Organizations. (JUN 2020) ([42 U.S.C. 1792](#)). Flow down required in accordance with paragraph (e) of FAR clause 52.226-6.

(U) [52.247-64](#), Preference for Privately Owned U.S.-Flag Commercial Vessels (NOV 2021) ([46 U.S.C. 55305](#) and [10 U.S.C. 2631](#)). Flow down required in accordance with paragraph (d) of FAR clause 52.247-64.



TALKAPHONE

Attachment A

EMERGENCY PHONE MOUNTS

ETP-MTE ECO TOWER™ EMERGENCY PHONE TOWER

THE ECO TOWER™ EMERGENCY PHONE TOWER, MODEL ETP-MTE, COMBINES ECONOMY AND ECOLOGY INTO ONE STYLISH PRODUCT. THE LIGHTWEIGHT ALUMINUM CONSTRUCTION REDUCES ITS ECOLOGICAL FOOTPRINT AND ALLOWS FOR ONE-PERSON INSTALLATION

FEATURES

- Light weight aluminum construction for reduced ecological footprint and one-person installation
- Durable, multilayer powder coating achieves near-zero waste and VOC (volatile organic compound) emissions
- Modular construction allows for easy upgrades
- Optimal internal mounting plates and shelves provide clean mounting solutions for accessories
- Emergency Phone is illuminated at all times by an LED Panel Light
- Vandal-resistant and designed to resist extreme weather conditions
- A variety of signage, graphics and color choices are available
- Easily mount any Talk-A-Phone ETP-400 Series or VOIP-500 Series Emergency/Information Phone into the unit (sold separately)
- ADA-compliant



ETP-MTE - ECO TOWER™
Emergency Phone TowerETP-MTE-W - Wireless/
Switched Power ECO TOWER™
Emergency Phone TowerETP-MTE-WP - Wireless ECO
TOWER™ Emergency Phone
Tower with Pole

Construction:	0.125 in. aluminum	0.125 in. aluminum	0.125 in. aluminum
Dimensions (WxDxH):	10.0 x 6.8 x 113.0 in. (254 x 171 x 2870 mm)	10.0 x 6.8 x 124.0 in. (254 x 171 x 3150 mm)	10.0 x 6.8 x 148.0 in. (254 x 171 x 3759 mm) including pole and Blue Light
Weight:	45 lbs. (20.4 kg)	50 lbs. (22.7 kg)	60 lbs. (27.2 kg)
Coating:	High-gloss, multi-layer, corrosion-inhibitive system with resistance to UV-fade and graffiti protection	High-gloss, multi-layer, corrosion-inhibitive system with resistance to UV-fade and graffiti protection	High-gloss, multi-layer, corrosion-inhibitive system with resistance to UV-fade and graffiti protection
Colors:	Blue and Red are standard. Available in custom colors.	Blue and Red are standard. Available in custom colors.	Blue and Red are standard. Available in custom colors.
Signage:	3.25 in. high reflective white "EMERGENCY" lettering with wide-angle visibility is standard. Available in custom colors, lettering, and graphics.	3.25 in. high reflective white "EMERGENCY" lettering with wide-angle visibility is standard. Available in custom colors, lettering, and graphics.	3.25 in. high reflective white "EMERGENCY" lettering with wide-angle visibility is standard. Available in custom colors, lettering, and graphics.
Lighting:	LED Blue Light: 209 lumens peak, 78 flashes per minute. 50,000 hour lifetime LED Panel Light: Ultra bright LEDs, 50,000 hour lifetime	LED Blue Light: 209 lumens peak, 78 flashes per minute. 50,000 hour lifetime LED Panel Light: Ultra bright LEDs, 50,000 hour lifetime	LED Blue Light: 209 lumens peak, 78 flashes per minute. 50,000 hour lifetime LED Panel Light: Ultra bright LEDs, 50,000 hour lifetime
Power:	9 watts, 12-24VDC, 24/120VAC	9 watts, 12-24VDC, 24/120VAC	9 watts, 12-24VDC, 24/120VAC
Mounting:	Mounts into concrete foundation using included hardware (shipped in advance). Mounting options available for pre-poured parking decks.	Mounts into concrete foundation using included hardware (shipped in advance). Mounting options available for pre-poured parking decks.	Mounts into concrete foundation using included hardware (shipped in advance). Mounting options available for pre-poured parking decks.
Warranty:	2-year warranty	2-year warranty	2-year warranty

ETP-MTE-ARM - ECO TOWER™
Camera Arm



ETP-MTE-72 - ECO TOWER™
Emergency Phone Tower



Construction:	0.125 in. aluminum	0.125 in. aluminum
Dimensions (WxDxH):	10.0 x 13.5 x 43.4 in. (254 x 344 x 1101 mm) not including LED Blue Light	10.0 x 6.8 x 72.0 in. (254 x 171 x 1829 mm)
Weight:	18 lbs. (8.2 kg) - Arm	30 lbs. (13.6 kg)
Coating:	High-gloss, multi-layer, corrosion-inhibitive system with resistance to UV-fade and graffiti protection	High-gloss, multi-layer, - corrosion-inhibitive system with resistance to UV-fade and graffiti protection
Colors:	Blue and Red are standard. Available in custom colors.	Blue and Red are standard. Available in custom colors.
Signage:	N/A	3.25 in. high reflective white "EMERGENCY" lettering with wide-angle visibility is standard. Available in custom colors, lettering, and graphics.
Lighting:	N/A	LED Blue Light: 209 lumens peak, 78 flashes per minute. 50,000 hour lifetime LED Panel Light: Ultra bright LEDs, 50,000 hour lifetime
Power:	N/A	9 watts, 12-24VDC, 24/120VAC
Mounting:	Camera mount has a 1.5" NPT adapter to mount a dome camera. Camera mount can be installed on any basic ECO TOWER emergency phone tower.	Mounts into concrete foundation using included hardware (shipped in advance). Mounting options available for pre-poured parking decks.

Approvals:	ETL Recognized Component -- Conforms to UL Standards 60950-1 and 60950-22. Certified to CSA Standard C22.2 Nos. 60950-1 and 60950-22.	 Intertek
-------------------	---	---

DIMENSIONAL DRAWING

All dimensions are in inches and are provided for reference only.

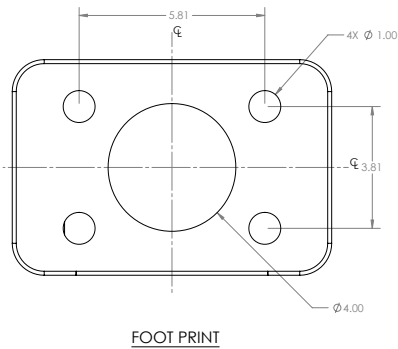
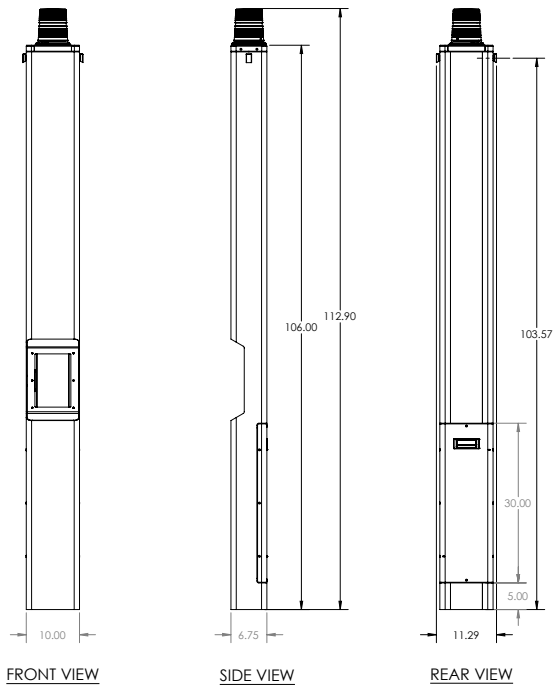

TALKAPHONE

THE LEADERS IN SECURITY AND LIFE SAFETY COMMUNICATIONS

7530 North Natchez Avenue
Niles, Illinois 60714

Tel: 773-539-1100
Email: info@talkaphone.com
Web: www.talkaphone.com

ACCESSORIES

Parking Deck Mounting Kit: Order model ETP-PDMK to mount on pre-poured parking deck.

Shelving: Order model ETP-MTE-SHELF to add an internal mounting shelf for accessories. Maximum two shelves per tower.

Mounting Panel: Order model ETP-MTE-PANEL to add an internal mounting panel for accessories. Maximum two panels per tower.

Emergency Phones

VoIP

Single Button Emergency Phone



VOIP-500



VOIP-600

Single Button Assistance Phone



VOIP-500C



VOIP-600H

Dual Button Emergency Phone



VOIP-500D



VOIP-600IE

Keypad Emergency Phone



VOIP-500K



VOIP-600ECK



ETP-WMS WALL MOUNT S CALL STATION SERIES





TALKAPHONE'S WALL MOUNT S EMERGENCY CALL UNIT IS AN IDEAL SECURITY SOLUTION FOR REMOTE AND HIGH-RISK AREAS. THE STATION OFFERS CONTEMPORARY ARCHITECTURAL STYLING AND IS CONSTRUCTED OF DURABLE 316 MARINE GRADE STAINLESS STEEL. AN ALWAYS-LIT LED BLUE LIGHT PROVIDES HIGH VISIBILITY AND GIVES PASSERS-BY A SENSE OF SECURITY. USERS CAN CALL EMERGENCY PERSONNEL WITH A SIMPLE PUSH OF A BUTTON.

FEATURES

- Attention-getting LED Blue Light is included and mounted inside a polycarbonate housing. The LED Blue Light is continuously lit and flashes for duration of a call when "EMERGENCY" button is pressed to draw attention to a unit.
- Emergency Phone faceplate is illuminated at all times by an LED Panel Light
- Vandal-resistant marine grade 316 stainless steel construction
- Designed to resist extreme weather conditions
- A variety of signage, graphics, and color choices are available
- Easily mount any Talkaphone ETP-500 Series, VOIP-500 Series, or VOIP-600 Series Emergency/Information Phone into the unit (sold separately).
- ADA-compliant

SPECIFICATIONS



Construction:	Brushed marine grade (316) stainless steel with impact- and UV-resistant polycarbonate lens.	
Dimensions (W x H x D):	10 x 32 x 4 in. (253 x 810 x 101 mm)	10 x 32 x 4 in. (253 x 810 x 101 mm)
Weight:	23 lbs. (10.4 kg)	
Colors:	Brushed stainless steel is standard. Available painted in custom colors.	
Lettering:	2 in. high reflective red "EMERGENCY" lettering with wide-angle visibility is standard. Available as "ASSISTANCE", "INFORMATION", or custom lettering, colors and graphics.	
Lighting:	<p>LED Blue Light: 78 flashes per minute, 70% of initial lumens after 50,000 hours of operation.</p> <p>LED Panel Light: Ultra bright LEDs, 50,000 hour lifetime.</p>	<p>LED Blue Light: 78 flashes per minute, 70% of initial lumens after 50,000 hours of operation.</p>
Power:	<p>LED Blue Light: 120VAC, 7.8 Watts, 35A peak inrush</p> <p>LED Panel Light: 1.2 watts, 12-24 VDC/VAC, 120VAC</p>	<p>LED Blue Light: 120VAC, 7.8 Watts, 35A peak inrush</p>
Mounting:	Mounts to a wall or straps to a pole or a kiosk.	
Warranty:	<p>2-year limited warranty for electronics</p> <p>5-year limited warranty for metal components</p>	
Approvals:	<p>  ETL Recognized Component -- Conforms to UL Standards 60950-1 and 60950-22. Certified to CSA Standard C22.2 Nos. 60950-1 and 60950-22. </p> <p>  </p>	

All specifications are subject to change without notice.

OPTIONS & ACCESSORIES

Add to Model:	Description:
-OP2	Includes a housing for mounting your own fixed CCTV camera (standard form factor with maximum camera depth of 3.5 in.) inside the wall mount above the emergency phone faceplate. Inquire for further details
OP3IP	Includes an AXIS Network Camera inside the wall mount above the emergency phone faceplate.

Pole Mounting Kit: Order ETP-PMKT-1 Pole Mounting Kit for strapping ETP-WMS Series or ETP-WMSE Series to a pole.

Strapping Tool: Order ETP-PMKT-TOOL Strapping Tool for use with ETP-PMKT-1 Pole Mounting Kit.

DIMENSIONAL DRAWING – ETP-WMS

All dimensions are in inches and are provided for reference only.

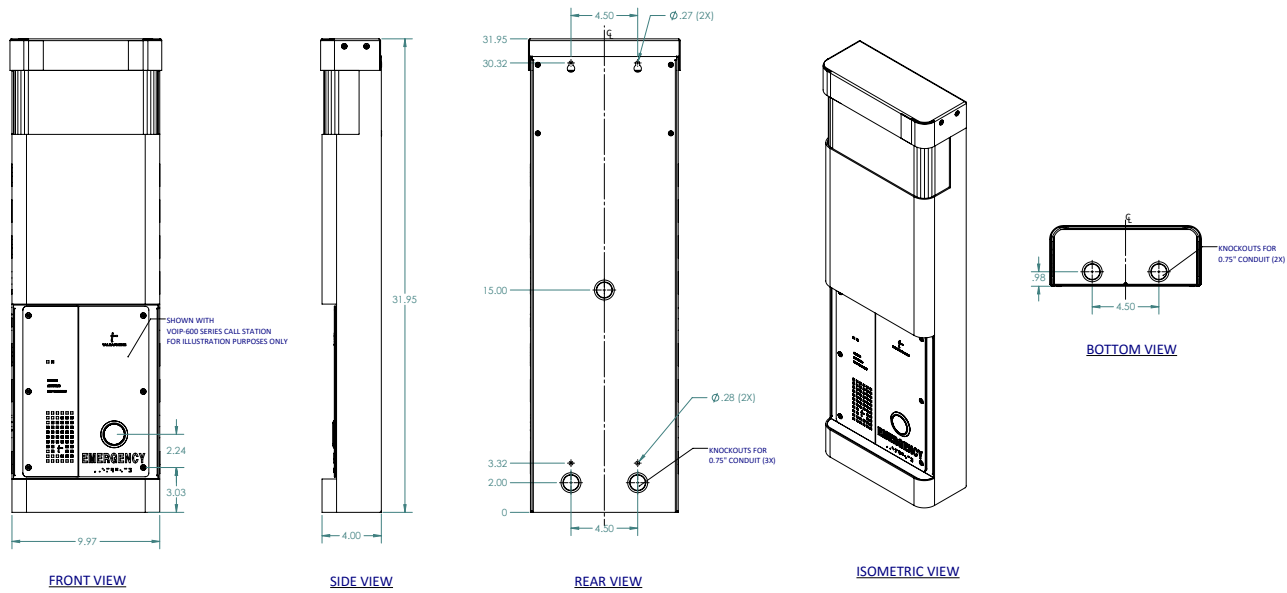

DIMENSIONAL DRAWING – ETP-WMSE

All dimensions are in inches and are provided for reference only.

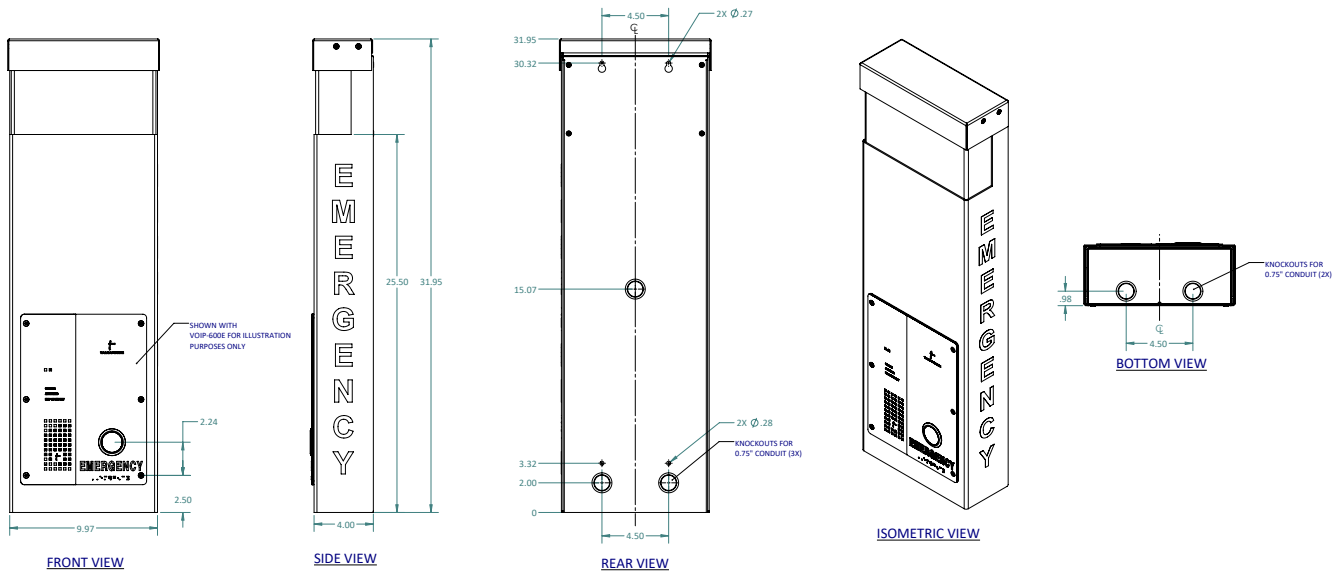

THE LEADERS IN SECURITY AND LIFE SAFETY COMMUNICATIONS

Tel: 773-539-1100
 Email: info@talkaphone.com
 Web: www.talkaphone.com

7530 North Natchez Avenue
 Niles, Illinois 60714

Terms of Use and Limited Warranty

This Product includes intellectual property and proprietary rights owned by Talk-A-Phone, LLC and/or its licensors. Your use of this Product confirms your agreement that Talk-A-Phone, LLC and/or its licensors retain all right, title and interest in and to all such property; that your rights are to access and use the Product for your internal business use only; that all Product elements will be maintained as confidential; and that the Product may not be rented, leased or lent to third parties, reverse engineered, decompiled or disassembled, or otherwise used for any purpose other than as an access device for your premises.

Talk-A-Phone, LLC warrants Talk-A-Phone Emergency Phone, Call Station, and Wide-Area Emergency Broadcast System equipment against any defects in material and workmanship, under normal use, for a period of twenty-four (24) months from date of installation, provided that Talk-A-Phone receives a completed "Installation Certification" certifying the date on which the system has been installed. An "Installation Certification" card is enclosed with every unit. In the event that no "Installation Certification" is received by Talk-A-Phone, the twenty-four (24) months will commence on the date of shipment by Talk-A-Phone. Warranty period for the metal elements of models in the GP Series Pedestals, MT Series Towers, MTE Series Towers, MT/R Series Towers, PM Series Pedestals, SM Series Surface Mounts, Via Series Mounts, and WM Series Wall Mounts is five (5) years, under the same terms and conditions. Warranty period for Area of Rescue Products is sixty (60) months, under the same terms and conditions. Warranty period for Intercommunication Products is twelve (12) months, under the same terms and conditions. If the Product is found by Talk-A-Phone to be defective within the warranty period, Talk-A-Phone's only obligation, and your exclusive remedy, is for the repair or replacement of any defective parts, provided that the Product is returned to us at 7530 N. Natchez Ave., Niles, IL 60714. Talk-A-Phone shall have no obligation to furnish or pay for the labor of any third parties or bear the expense of shipping defective Products for repair. In no event shall Talk-A-Phone or its licensors or suppliers be liable for any form of exemplary or punitive damages, or any special, indirect or consequential damages. TALK-A-PHONE EXPRESSLY DISCLAIMS ALL OTHER WARRANTIES, WHETHER EXPRESS, IMPLIED OR STATUTORY, INCLUDING BUT NOT LIMITED TO THE IMPLIED WARRANTIES OF MERCHANTABILITY OR FITNESS FOR A PARTICULAR PURPOSE. In no event shall Talk-A-Phone or its licensors or suppliers be liable for any form of exemplary or punitive damages, or any special, indirect or consequential damages. Your use of this Product constitutes your agreement to all of the foregoing terms.

THIS WARRANTY GIVES YOU SPECIFIC LEGAL RIGHTS AND YOU MAY ALSO HAVE OTHER RIGHTS WHICH VARY FROM STATE TO STATE. Further information is available at talkaphone.com/legal

Copyright 2021 Talk-A-Phone, LLC All Rights Reserved - Rev. 2/16/2021

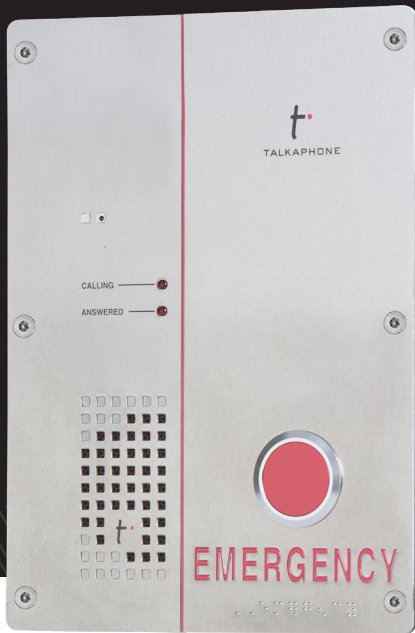

VOIP-500 SERIES IP CALL STATION

CALL STATIONS

VOIP-500 SERIES OUTDOOR- RATED, ADA-COMPLIANT HANDS- FREE VOICE OVER IP (VOIP) CALL STATIONS GO BEYOND EMERGENCY COMMUNICATIONS WITH INTELLIGIBLE AUDIO PAGING, SILENT MONITORING AND ADVANCED SELF-DIAGNOSTIC AND REPORTING FEATURES.



Talkaphone's VOIP-500 Series Call Station has tested compatible with Cisco UCM 7.1 and UCM 8.6. The Cisco Compatible logo signifies that Talkaphone's product has undergone interoperability testing by Talkaphone together with Cisco and a third-party test house based on testing criteria set by Cisco. Talkaphone is solely responsible for the support and warranty of its product. Cisco makes no warranties, express or implied, with respect to Talkaphone's product or its interoperation with the listed Cisco product(s) and disclaims any implied warranties of merchantability, fitness for a particular use, or against infringement.

Talkaphone's VOIP-500 Series and VOIP 600 Series Call Stations directly support the Singlewire InformaCast IP Speaker Protocol. Singlewire InformaCast Advanced is a full-featured emergency notification solution that enables people to reach Cisco IP phones, speakers, cell phones (with InformaCast Mobile), and other devices with text and live, ad-hoc, pre-recorded, or text-to-speech audio.

This integration and direct support offers organizations the opportunity to leverage the SIP-compliant VOIP-500 Series and VOIP-600 Series Call Stations as endpoints for triggering and receiving InformaCast broadcasts. In addition to being capable of receiving live, ad-hoc, pre-recorded, or text-to-speech audio, the VOIP-500 Series and VOIP-600 Series Call Stations button can be configured to place a call to a preset extension phone number. Singlewire InformaCast Advanced can be configured to monitor that extension phone number utilizing the CallAware module and, as a result, trigger a broadcast.

FEATURES

- Exceptional sound clarity during conversation (over 90dB, configurable) and paging (over 100dB, configurable)
- Unit can be paged remotely as part of direct support from Singlewire InformaCast IP Speaker Protocol, capable of alerting your audience through Cisco IP phones or by placing a call into the unit
- Ethernet connectivity and full IP compatibility with existing routers and LAN infrastructure
- Additional Layer 2 switch Ethernet port to provide a passthrough network connection for other devices (e.g. IP Video Cameras)
- Supports standard SIP protocol
- Configuration and firmware upgrades through Web GUI
- Power over Ethernet (PoE, 802.3af), 12V DC, 24V AC/DC
- Vandal resistant 316 marine grade stainless steel faceplate
- Two LED indicators for hearing impaired (calling, answered)
- Built-in auto-dialer can dial six numbers: if first number does not answer or is busy, dials next number
- Auto-answer allows security to monitor and initiate calls with the unit
- Automatically inform the attendant of an IP call station's location
- via recorded message
- Self-diagnostic testing of built-in buttons, microphone and speaker on schedule and fault reporting

GENERAL SPECIFICATIONS	
Construction:	0.086 in (2.13mm) #4 brushed 316 stainless steel faceplate
Front Panel Dimensions (WxH):	8.5 x 11.5 in. (216 x 292 mm)
Back Box Dimensions (WxHxD):	6.38 x 9.79 x 2.83 in. (162x 72 x 249 mm)
Weight:	5 lbs. (3.6 kg)
Storage Temperature:	-40° F to +149° F (-40° C to +65° C)
Operating Temperature:	-40° F to +131° F (-40° C to +55° C)
Relative Humidity:	Up to 95% non-condensing
Protection:	IP66, Circuit board conformal coated
Mounting:	Flush mount (surface mount options available)
Communication:	Full duplex two-way hands-free communication
Digit Capacity:	Up to 30-digits, including pauses, for each of six phone numbers
Call Control Signaling:	SIP (RFC 3261 compliant)
Audio Codecs:	G.711 PCM a-Law @ 64kbps, G.711 PCM u-Law @ 64kbps, G.729a, G.723.1a
Power:	Nominal: +12VDC (500mA), +24VAC/DC (300mA), or PoE (+36VDC - 57VDC, 150mA) Max: +12VDC (800mA), +24VAC/DC (500mA), or PoE (+36VDC - 57VDC, 250mA) NOTE: If not connecting PoE, a dedicated line regulated power supply required.
Auxiliary Contacts:	(3) Aux Inputs: dry contact, 10mA @ 8VDC (3) Aux Outputs: dry contact, 120mA @ 120VAC/ DC
Network:	10/100 BaseT Ethernet, RJ45 connectors, Cat 5e or better
Programming:	Non-volatile flash memory programming and configuration through Web GUI
Configuration:	Static IP address provisioning and DHCP client. Monitoring via Syslog application
Self Diagnostics:	Checks the status of built-in buttons, microphone, speaker, and optional WEBS® speaker array. The results are reported via email, phone call, or activation of auxilliary output interface.
Compliance	FCC Part 15, Subpart B, Class A ANSI/UL Standard 60950-1 and 60950-22 certified to CAN/ CSA Standard C22.2 No. 60950-1 and 60950-22
Approvals:	ETL Listed -- Conforms to ANSI/UL Standards 60950-1 and 60950-22. Certified to CAN/CSA Standard C22.2 Nos. 60950-1 and 60950-22.  Intertek



VOIP-500H

IMPORTANT NOTE: Not all features of the VOIP-500 Series Call Station are available when used in conjunction with analog telephony adaptor devices or with Public Switched Telephone Network (PSTN). For example, the round robin dialing feature (See "VOIP-500 Configuration and Operation Manual", Section 4.5.1) and voice message functionality (See "VOIP-500 Configuration and Operation Manual", Section 4.7) of the VOIP-500 Series Call Station may not operate as described in the manual when used in conjunction with equipment such as a Model VOIP-1-2-4-8 interface, 3rd party gateways, and/or PSTN interfaces such as T1, PRI, or loopstart trunks.

**VOIP-500EI - Dual Button Native
VoIP Call Station**



Buttons: Two

Verbiage: Info, Emergency

Keypad: No

VOIP-500ECK - Native VoIP Keypad Call Station



Buttons: Two

Verbiage: Call, Emergency

Keypad: Yes

**VOIP-500E - Single Button Native
VoIP Emergency Call Station**



Buttons: One

Verbiage: Emergency

Keypad: No

**VOIP-500C - Single Button Native
VoIP Assistance Call Station**



Buttons: One

Verbiage: Call

Keypad: No

TERMS OF USE AND LIMITED WARRANTY

Talk A Phone, LLC warrants Talk A Phone Emergency Phone, Call Station, Wide Area Emergency Broadcast System, and Area of Rescue equipment against any defects in material and workmanship, under normal use, for a period of twenty four (24) months from date of installation, provided that Talk A Phone receives a completed "Installation Certification" certifying the date on which the system has been installed. An "Installation Certification" card is enclosed with every unit. In the event that no "Installation Certification" is received by Talk A Phone, the twenty four (24) months will commence on the date of shipment by Talk A Phone. Warranty period for the metal elements of models in the GP Series Pedestals, MT Series Towers, MTE Series Towers, MT/R Series Towers, PM Series Pedestals, SM Series Surface Mounts, Via Series Mounts, and WM Series Wall Mounts is five (5) years, under the same terms and conditions. Warranty period for Intercommunication Products is twelve (12) months, under the same terms and conditions.

THIS WARRANTY GIVES YOU SPECIFIC LEGAL RIGHTS AND YOU MAY ALSO HAVE OTHER RIGHTS WHICH VARY FROM STATE TO STATE.

DIMENSIONAL DIAGRAMS

All dimensions are in inches and are provided for reference only. Model VOIP-500E shown.

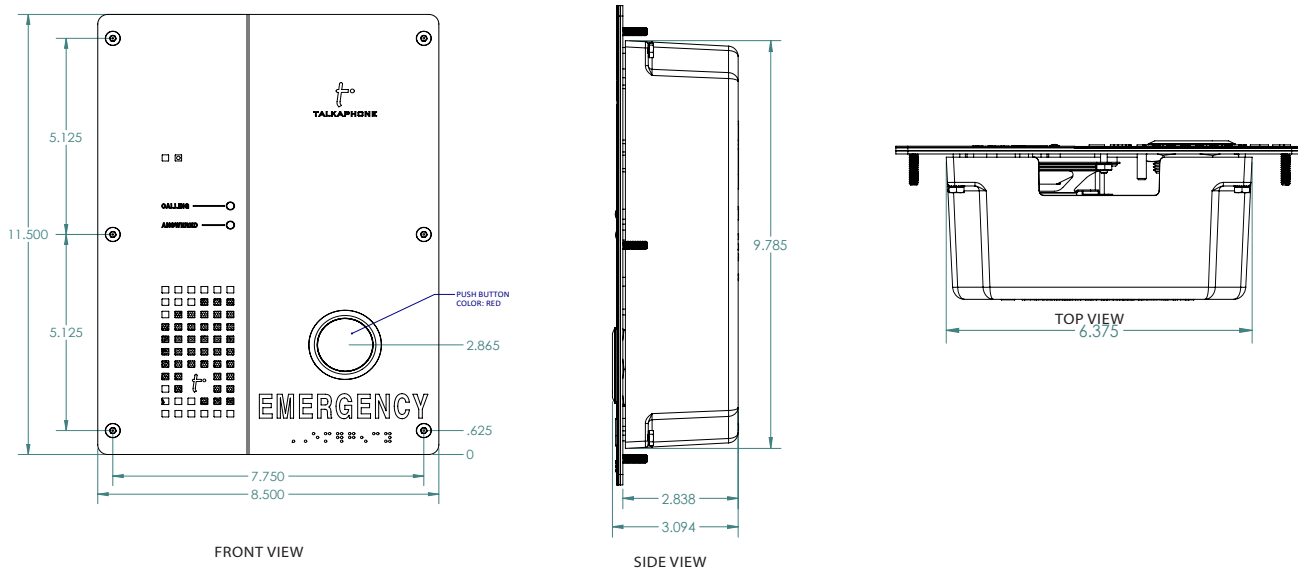

ORDERING INFORMATION

Switch 1	Switch 2	Switch 3/ Switch 4	Keypad	Handset	Camera	Lock	Audible Signal Device	Volume Control	LEDs
A Red button with ASSISTANCE signage	<NULL> No black button, no associated signage	<NULL> No Switch 3	<NULL> No Keypad	<NULL> No Handset	<NULL> No integrated mini camera	<NULL> No keylock switch	<NULL> No audible signal device	<NULL> No volume control	<NULL> No integrated mini camera
C Red button with CALL signage	A Black button with ASSISTANCE signage	Q Switch 3	K Integrated Keypad	F Armored cord handset w/ push-to-talk switch, no built-in speaker/mic	3 Integrated mini camera	L Keylock switch installed onto faceplate and wired to Auxiliary Input Interface	U Sonalert installed onto faceplate and wired to Auxiliary Output Interface	V Volume control	3 Integrated mini camera
E Red button with EMERGENCY signage	C Black button with CALL signage	R Switch 3 and Switch 4		FM Armored cord handset w/ push-to-talk switch, w/ built-in speaker/mic					
H Red button with HELP signage	H Black button with HELP signage			G Armored cord handset w/ volume control switch, no built-in speaker/mic					
I Red button with INFO signage	I Black button with INFO signage			GM Armored cord handset w/ volume control switch, w/ built-in speaker/mic					
N No red button, no associated signage	S Black button, no associated signage			P Armored cord handset, no built-in speaker/mic					
S Red button, no associated signage				PM Armored cord handset, w/ built-in speaker/mic					
Example: VOIP-500-ECK									
E-	C-		K						



TALKPHONE

THE LEADERS IN SECURITY AND LIFE SAFETY COMMUNICATIONS

7530 North Natchez Avenue
Niles, Illinois 60714

Tel: 773-539-1100
Email: info@talkphone.com
Web: www.talkphone.com

Rev. 02.05.2019